

A collaborative paradigm for human workers and multi-robot teams in precision agriculture systems.

Team:

- *Giuseppe Valenzano*
- *Francesco Messina*

La nascita di Canopies

FIRA

INTERNATIONAL FORUM OF AGRICULTURAL ROBOTICS

10 & 11 december 2019

Toulouse, France

- Dicembre 2018 1° FIRA;
- Incontro a Dicembre 2019 con Prof. Andrea Gasparri;
- Giugno 2020 sottomissione della Proposal;
- Settembre 2020 vincita bando H2020.

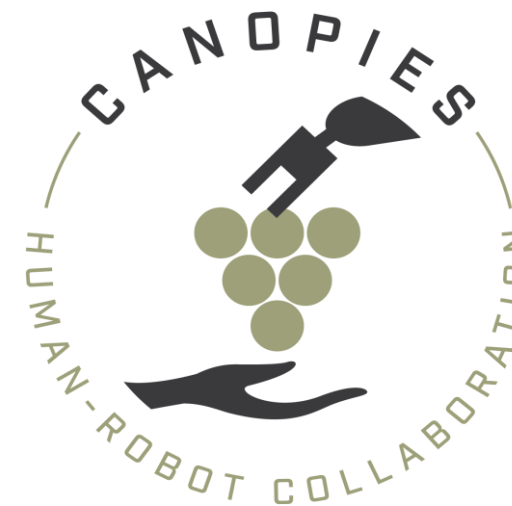

- Finanziamento complessivo di 7 milioni di €;
- Durata di 4 anni (2021 – 2024);
- 10 partner europei di cui:
 - 4 università;
 - 4 aziende private;
 - 2 istituti di ricerca.



agriMessina



RSA



This project is funded by the European Union
G.A. No 101016906

Obiettivi di Canopies



Fronteggiare l'elevata carenza di manodopera a livello globale



Riduzione dei costi di raccolta



Effettuare una raccolta selettiva: raccogliere un prodotto che abbia le caratteristiche qualitative desiderate

La Vision di Canopies

A collaborative paradigm for human workers and multi-robot teams in precision agriculture systems

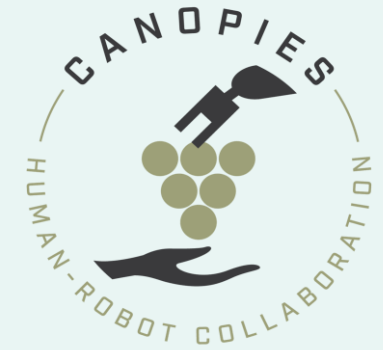

2 Robot che lavorano in maniera collaborativa fra loro e con gli operatori.



Harvest Robot



Logistic Robot

Robot - Overview

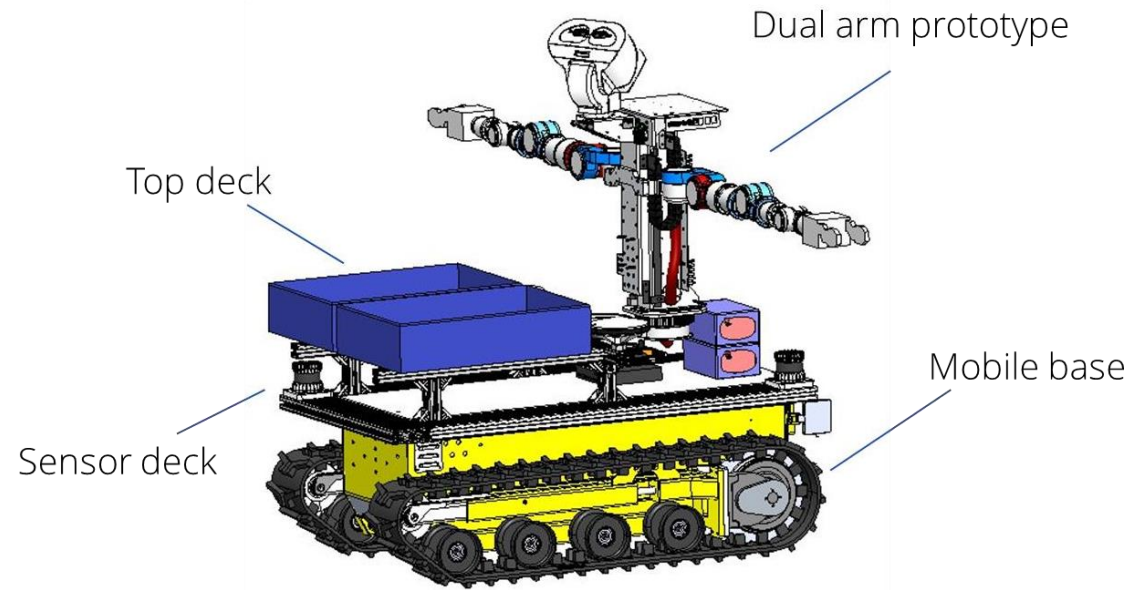

- Mobile base;
- Reachability study;
- Dual Arm system;
- Torso;
- End effector;
- Box Exchange mechanism;
- Human - Robot interaction;
- Virtual reality;

Conveyor – Active alignment

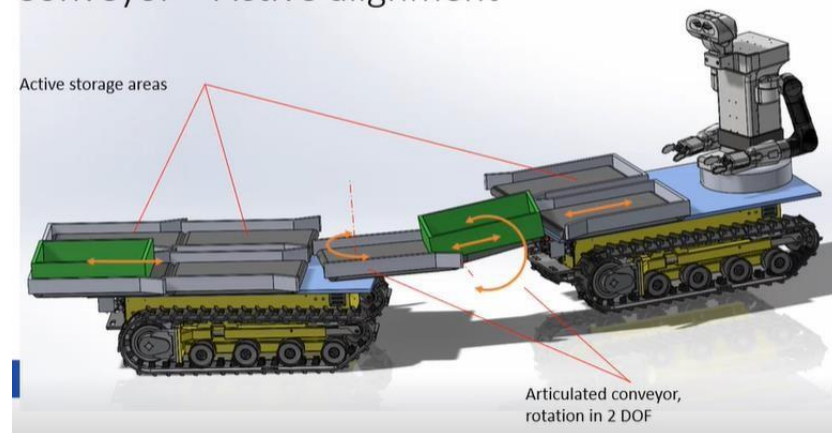

This project is funded by the European Union
G.A No 101016906



DANISH
TECHNOLOGICAL
INSTITUTE

PaleBlue

PAL
ROBOTICS



agriMessina



RSA



Robot - Mobile base

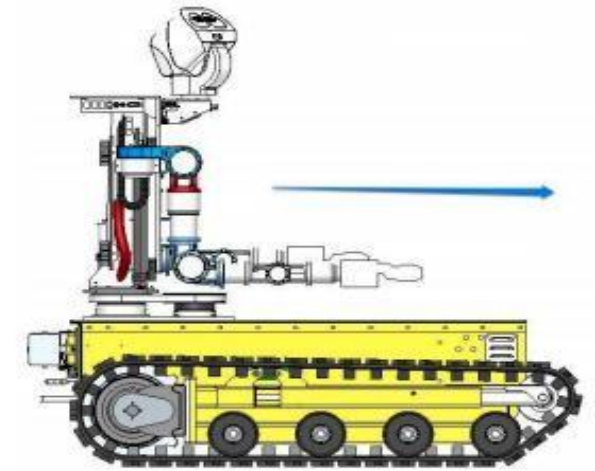
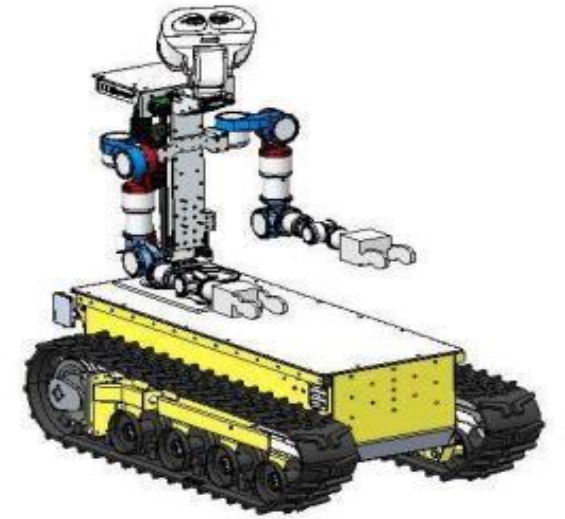
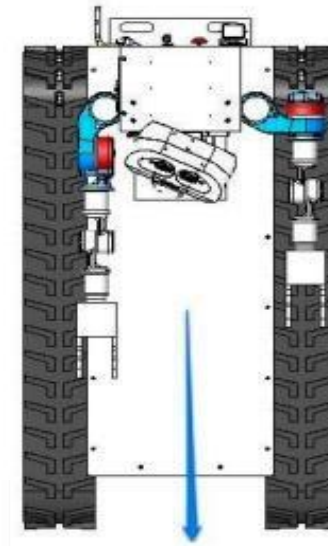
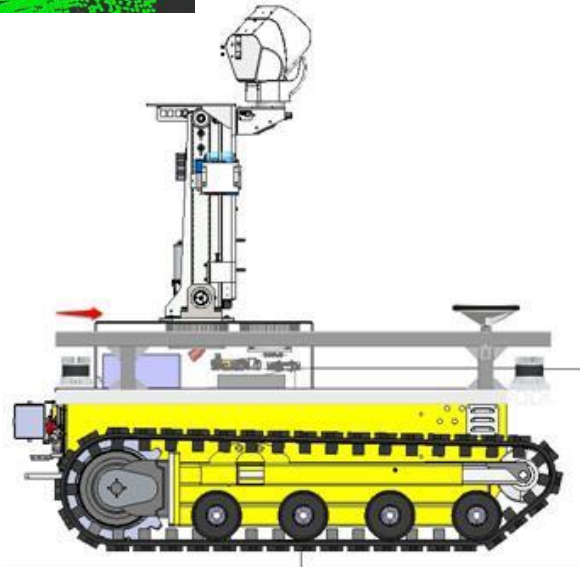
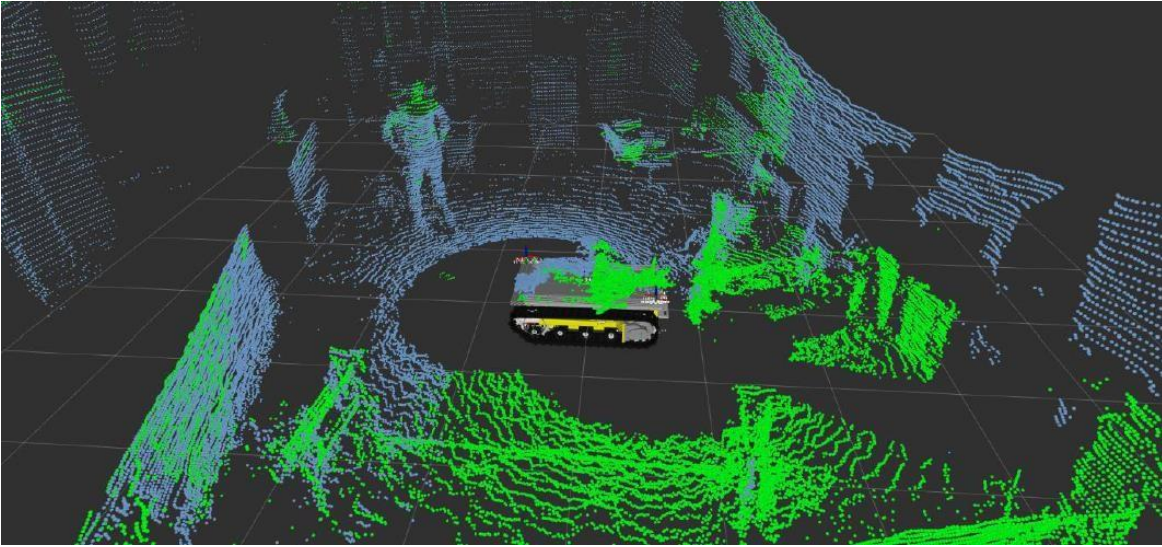

This project is funded by the European Union G.A No 101016906



DANISH TECHNOLOGICAL INSTITUTE

PaleBlue

PAL ROBOTICS



agriMessina



RSA



Robot - Dual arms system & Torso

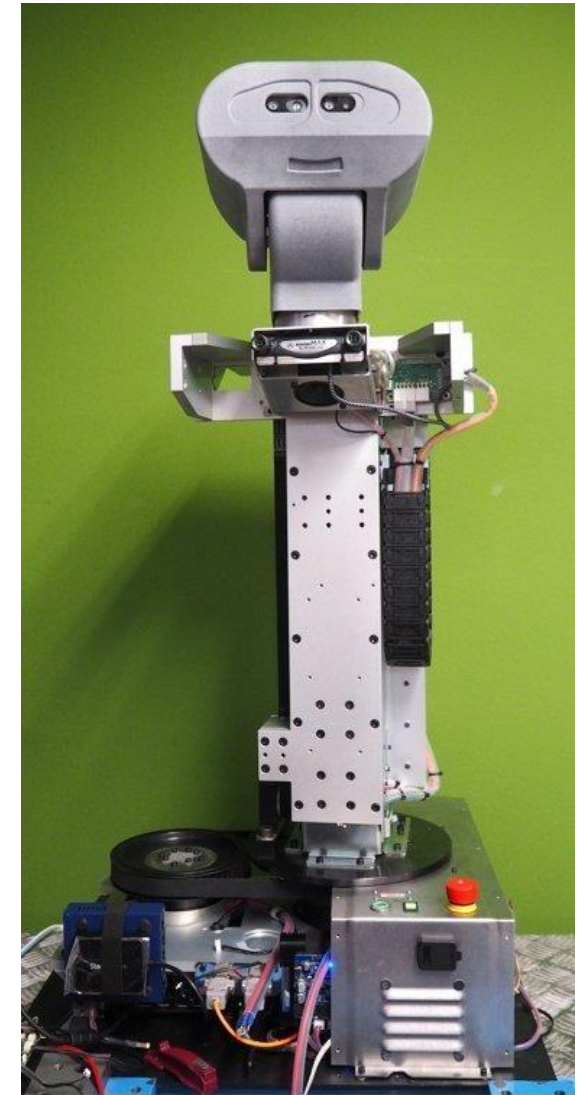
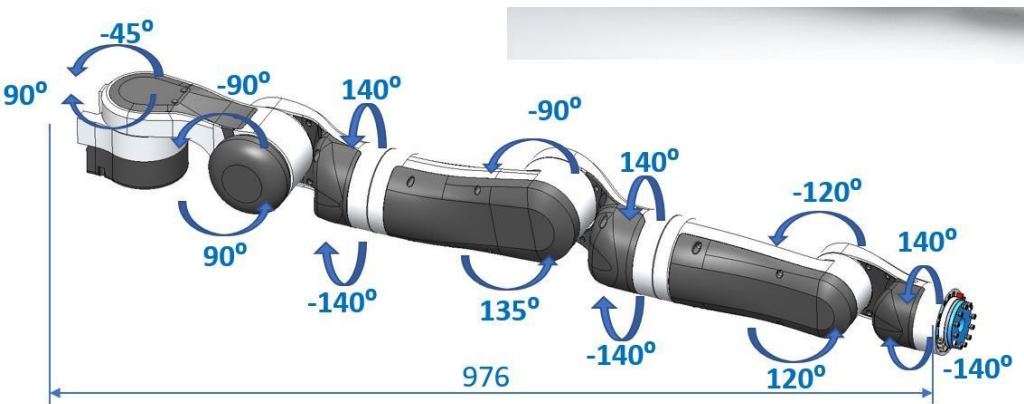
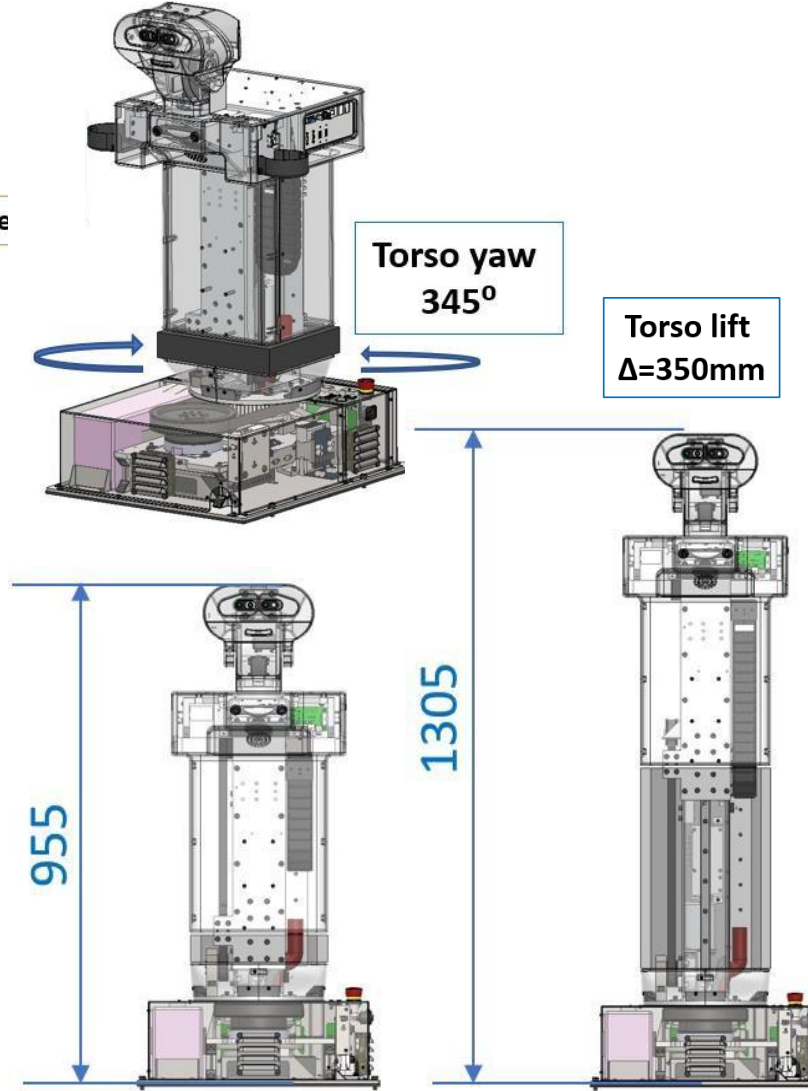
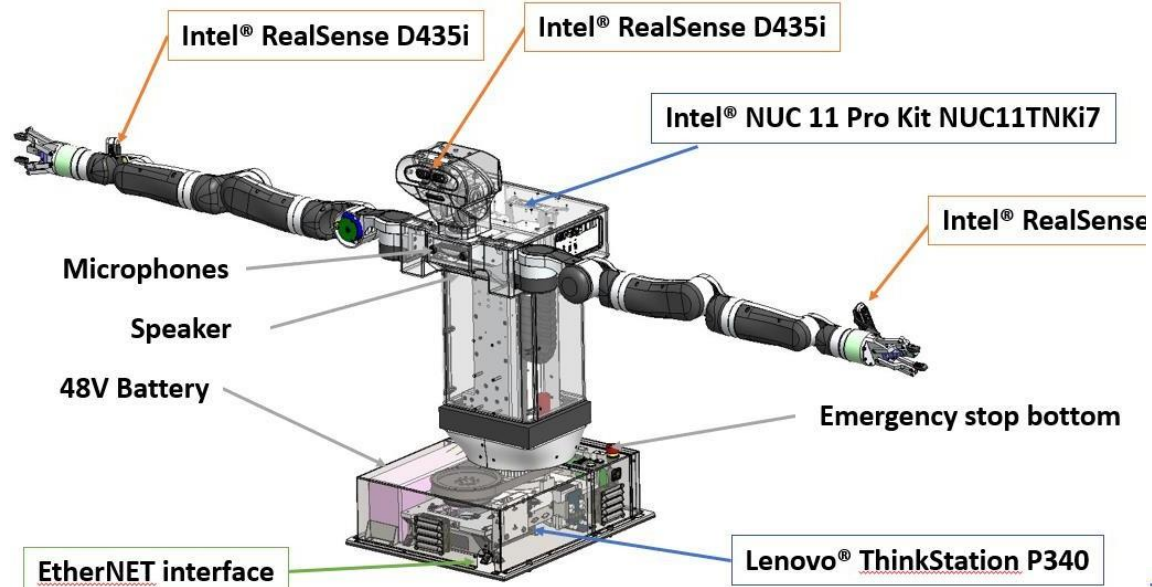

This project is funded by the European Union G.A No 101016906



agriMessina



RSA



Robot - Reachability study

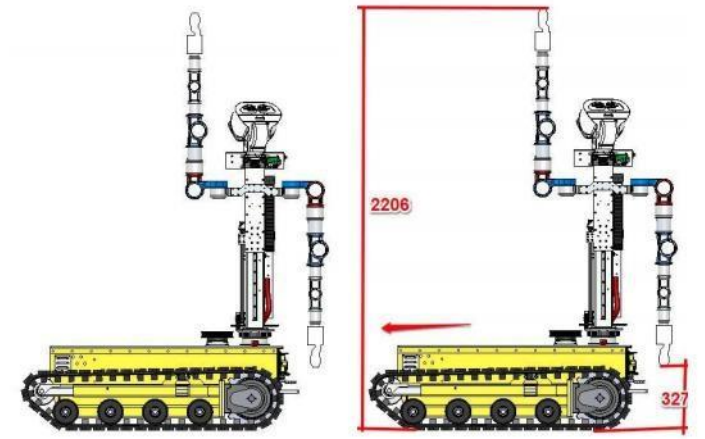
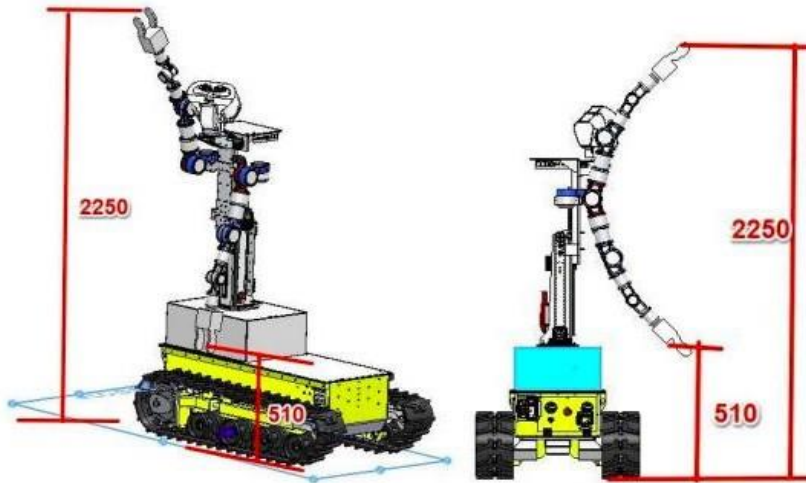
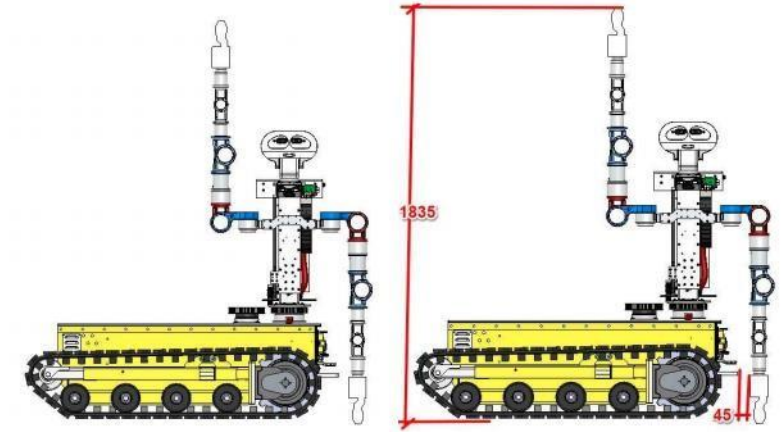
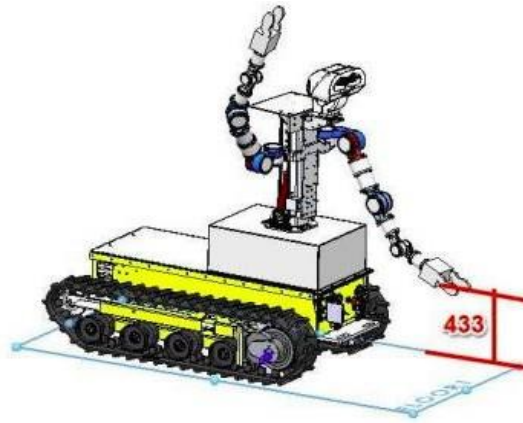
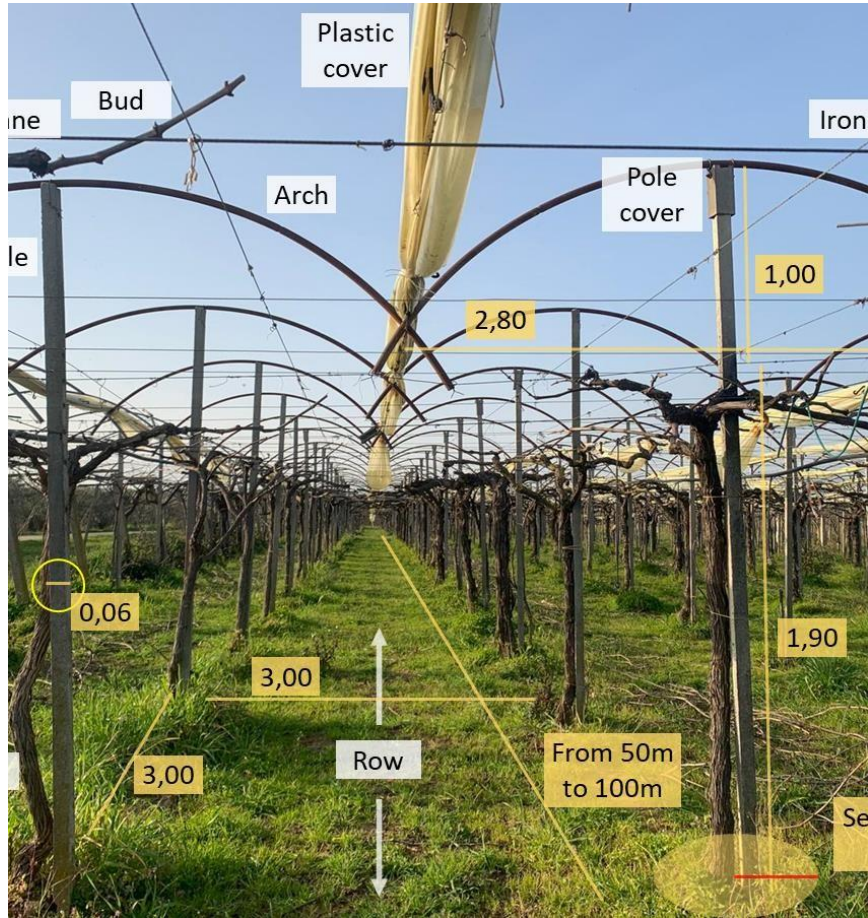

This project is funded by the European Union G.A No 101016906



DANISH TECHNOLOGICAL INSTITUTE

PaleBlue

PAL ROBOTICS



agriMessina



RSA



Robot - End Effector



Agronomic perception

- Rilevamento grappolo e peduncolo
- Rilevamento tralci;
- Determinazione della qualità dell'uva, relativa maturazione e presenza di difetti/imperfezioni.



RGB-D sensors + GNSS +
Multispectral sensor

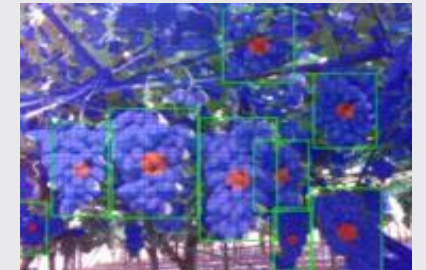

This project is funded by
the European Union
G.A No 101016906



DANISH
TECHNOLOGICAL
INSTITUTE

PaleBlue

PAL
ROBOTICS



agriMessina



RSA



Robot - Box exchange mechanism

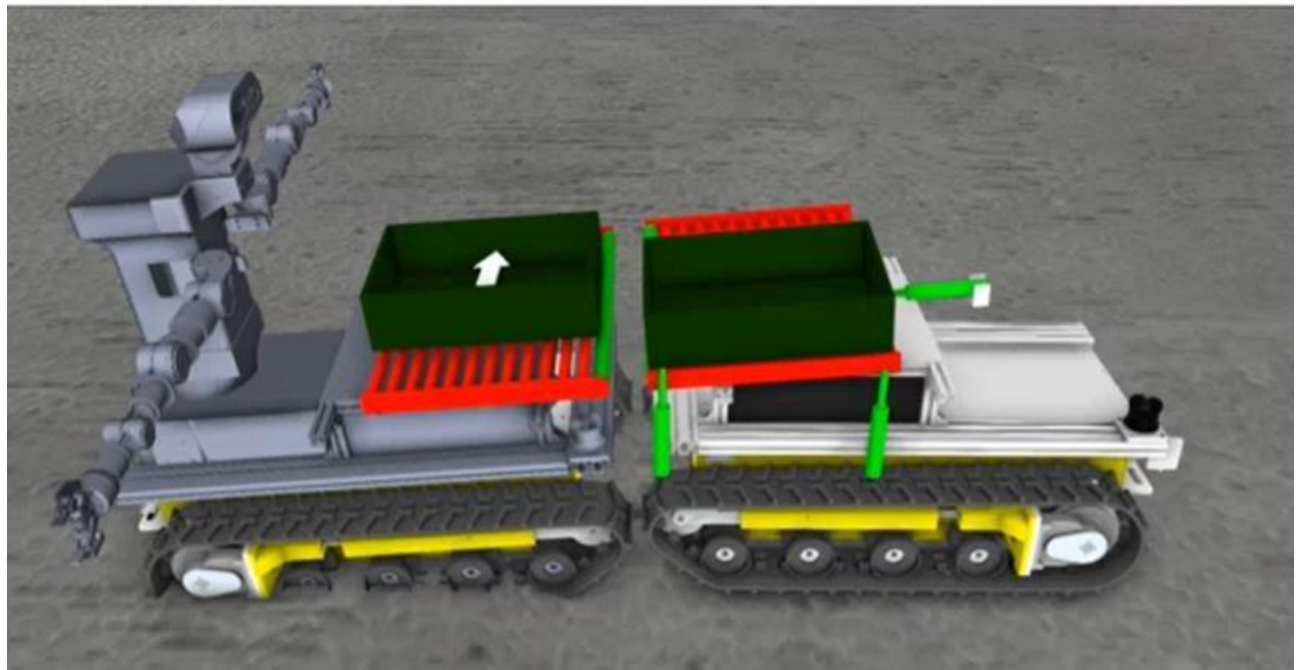
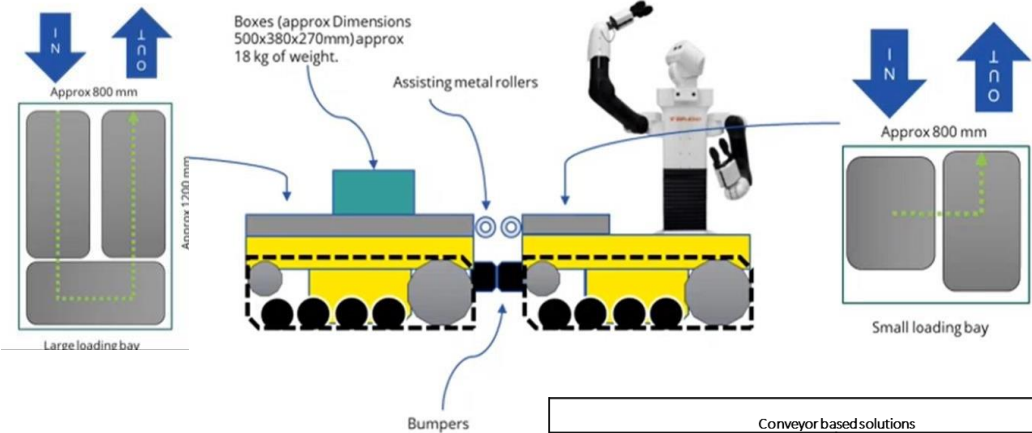

Conveyor based solutions	
mechanical alignment	articulated conveyor

misc		mechanical alignment	articulated conveyor
Docking orientation		head-to-head	1 of any
# empty slots for exchanging full for empty box		2	2
KPIs			
hardware complexity		medium	high
software complexity		low	medium
overall robustness		?	?
which platform required an active mechanisms		both	both
off-the-shelf-components		medium	few
number of active mechanisms		4+	4+
Requirements			
max. footprint on farming robot	850x900mm	+	+
max. footprint on logistic robot	850x1500 mm	?	?
max. Height on logistic robot	1.5 m	?	?
TRL	6	+	?
min. boxes on farming robot	2	+	+
min. boxes on logistic robot	4	o	o
ingress protection (IP rating)	IP54 or better	+	o
max. Price of modules	budget is 12k€ for farming, 24k€ logistic robot	+	?
max. roll alignment error	±10 deg	+	+
max. yaw alignment error	±20 deg	+	+
max. Out-of-horizontal alignment error	±10 deg	+	+
max. Horizontal alignment error	±100 mm	+	?
max. Vertical alignment error	±50 mm	+	+
max. gap between robots	±150 mm	+	+
sensor types	rugged enough for environment	+	?
box weight	up to 10 kg	+	+
distribution of mechanisms	active components only on one robot	-	-

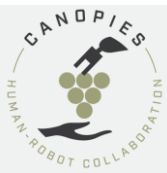
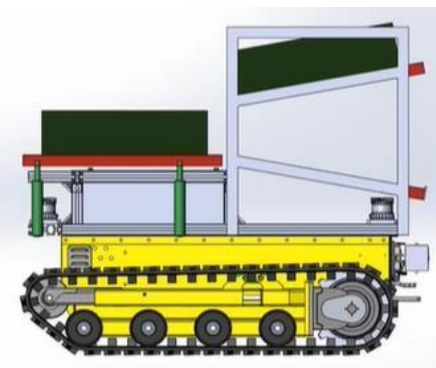

Robot - HR Interaction

	Information	Command	Alert	Request	Instruction	Greeting
Voice	✓			✓		✓
Gesture		✓				
Sound			✓			
Visual Signals	✓		✓		✓	

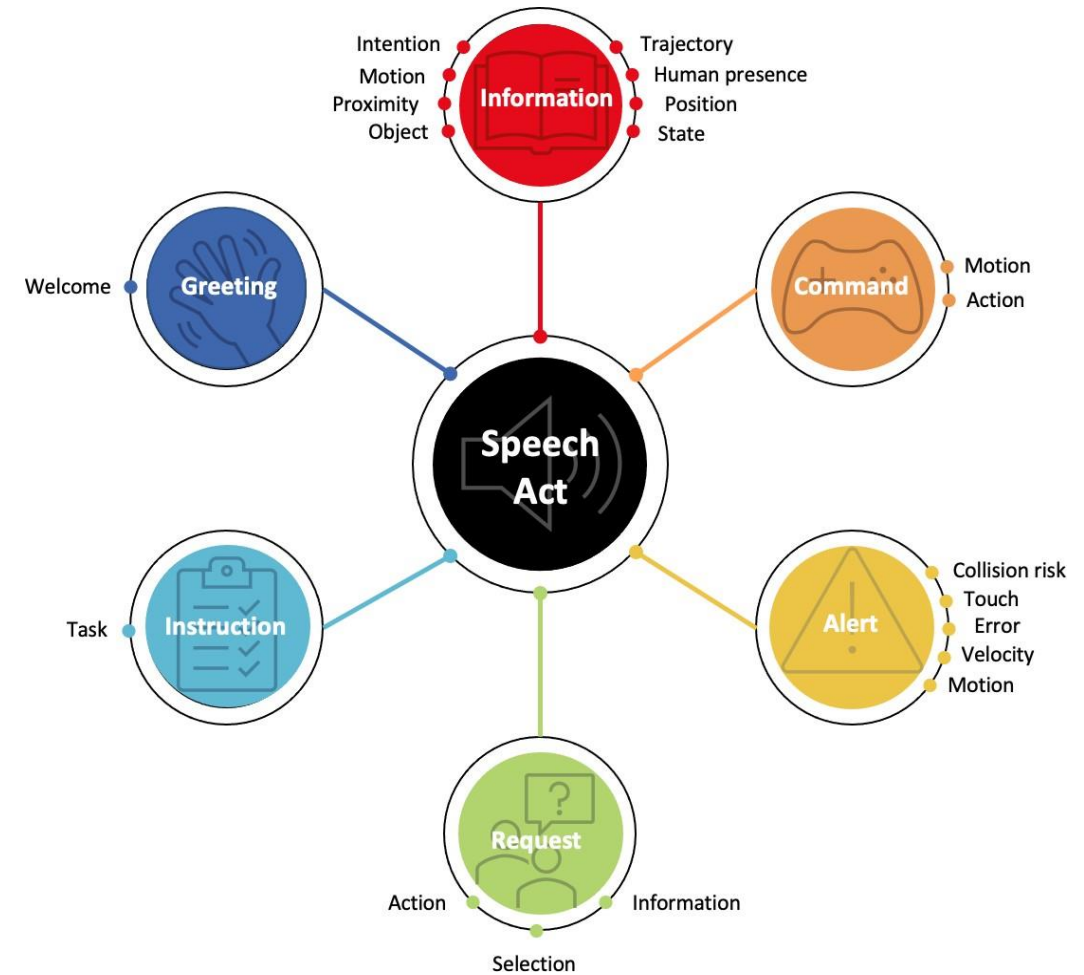
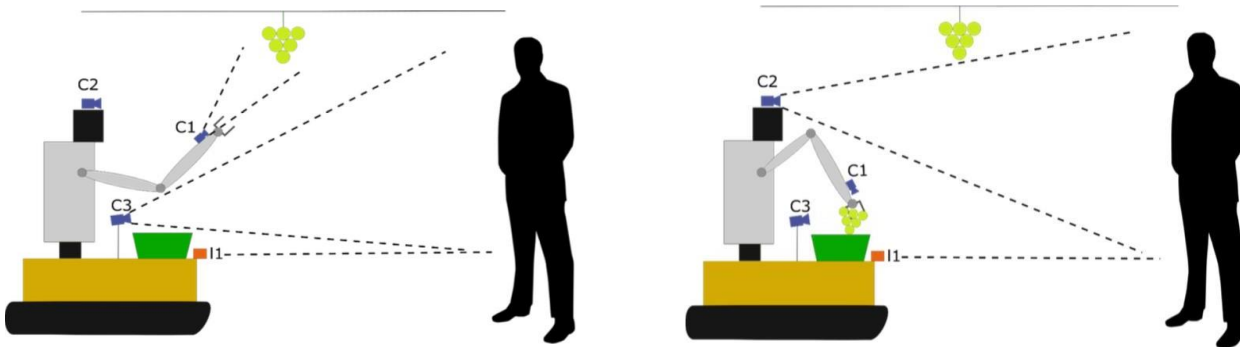

This project is funded by the European Union G.A No 101016906



DANISH TECHNOLOGICAL INSTITUTE

PaleBlue

PAL ROBOTICS



agriMessina



RSA



Robot - Virtual Reality

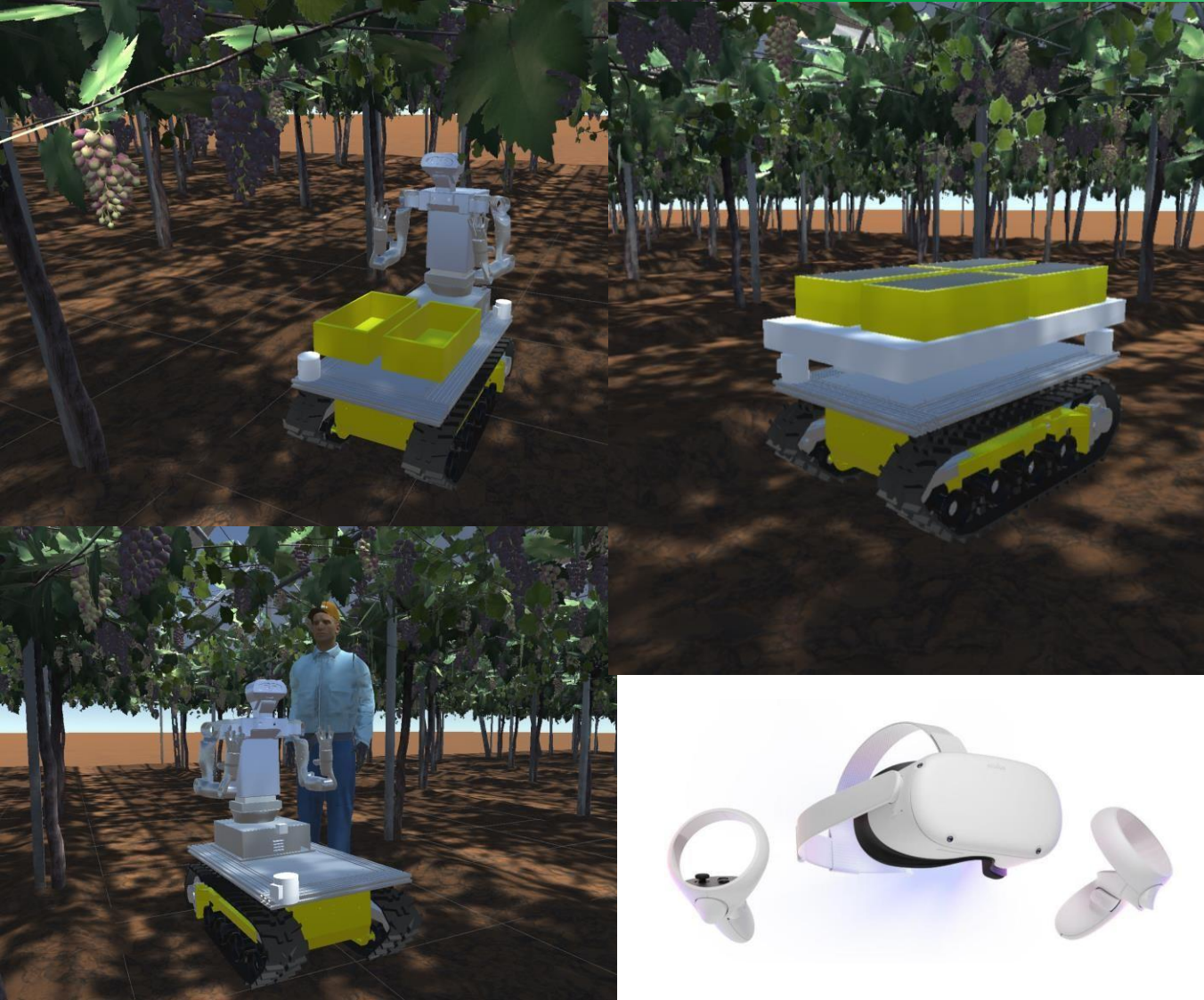

This project is funded by the European Union G.A No 101016906



DANISH TECHNOLOGICAL INSTITUTE

PaleBlue

PAL ROBOTICS



agriMessina



RSA



